

PROJECT 5

The purpose of this assignment is to further explore typographic hierarchy as well as to begin to understand grids. A grid is the skeleton or framework that allows for arranging content within the space of the page. It is the building block of all digital images and marks and is not a rigid formula, but instead a flexible, resilient structure. While single-column grids work well for simple documents, multicolumn grids provide flexible formats for publications that have a complex hierarchy or that integrate text and illustrations. The more columns you create, the more flexible your grid becomes.

For the assignment, you will create a spread (two pages that face each other, books and magazines are designed using spreads) that incorporate a type designer and one of their fonts. I recommend that you not choose a free font because you will not be able to find the necessary information to complete the assignment. The typeface you choose needs to be the typeface used in the design so that should also be concern for you. The goal of the spread is to showcase both the designer and the typeface in the composition. You will be producing the written content as part of Exercise 5. This will serve as the text for the project. Your project needs to contain at minimum:

- Name of Type Designer
- Designer's Birthdate (and Death date if applicable)
- Basic biographical information about the designer
- Name of Typeface
- Classification of Typeface
- Year Typeface was created
- Information about the typeface

There are no specifics on how the information must be treated in terms of hierarchy, but you need to have at least two paragraphs of text as part of the composition. The layout could go the route of a magazine layout or be more like a type specimen.

INSTRUCTIONS

1. Choose a type designer and one of the typefaces they have created (or you could choose a typeface and then find out who the type designer was). I recommend staying away from the free fonts you find online because you will be hard pressed to find the information needed to complete the assignment. You should complete Exercise 5, the research stage of the project, before proceeding.
2. After completing your research, you should begin brainstorming about how you will layout your two page spread. You need to complete a minimum of 20, two-page thumbnails (see the lecture notes for examples). Explore a variety of options for you hierarchy and for your grid system.
3. Review your sketches with me. Decide on which one you would like to pursue.
4. Begin creating your two page layout in InDesign. Your pages should be 8.5" x 11". Make sure the Facing Pages option is checked and start your number on page two so you can see both pages at the same time. Determine the number of columns for your chosen grid and your margins. You must use the typeface you choose as the font for your project, but may use any weight/style of it that you like within the design. The composition may include a picture of your designer (make sure to give an image credit). The image should be CMYK and at 300 dpi. It should also include letters and punctuation from the typeface. You may additionally use basic shapes in the composition. All colors should be CMYK and should be added to your swatches.
5. Print a preliminary copy of your layout for me to review.
6. Make any necessary revisions to the layout. You will then print the spread on one piece of 11" x 17" (or on 12" x 18" and cut to size if using bleeds). The lab assistant or myself can assist you with this task. Then, mount the completed project on a 13" x 19" piece of foam core.
7. Place a label on the back as per the syllabus and a cover.

SUBMISSION GUIDELINES

Project will be presented in mounted form. You should have two pages when completed— each 8.5" x 11" — printed side by side on an 11" x 17" sheet of paper (or on a 12" x 18" piece of paper and cut to size if using bleeds). It should then be mounted on a 19" x 13" piece of black foam core with a 1" margin around the entire composition. There should be no space between the pages of the composition. Make sure to place all digital files including fonts on class shares. I will show you how to Package your InDesign files to make this easier.

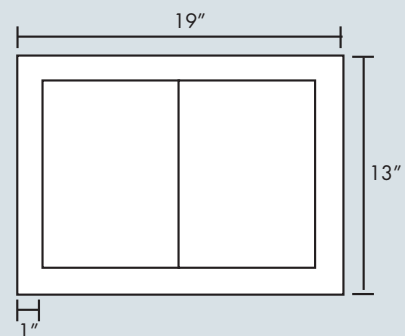

DUE DATES

Project should be submitted at the start of class on March 25.

We will critique the projects in class. Please be prepared to participate in the critique and explain your work.

QUESTIONS

Katie Krcmarik
P: 248-321-3434 (cell)
kkrcmarik@hotmail.com

Office Hours:

Varies, but I will be available on campus Mon, Tues, Wed, and Thurs.